

Technicians Manual

INSTALLATION & ADJUSTMENT

OPERATION & CONTROL

Exhaust air filter, article No: G10125
Supply air filter, article No: G10126

*Easy to
maintain*

*Efficient
heat recovery*

*Low noise
level*

*Low energy
consumption*



	Page		
Installation & Adjustment			
Safety and Security	3	2.7. Heater	22
Receipt of Delivery	3	Type of heater	
Installation	3	Electric heater	
Mounting	3	Water heater	
Installation of Water-Resistant Substrate	3	Anti-freeze function	
Anti-tip Protection	3	Exercise of valve	
Condensate Drain	3	2.8. Defrosting	23
The Duct System	3	Outdoor temp limits 1	
Silencing	3	During defrost 1	
Placing of Temperature Sensors	4	Outdoor temp limits 2	
Insulation	4	During defrost 2	
Open Fireplace	4	Outdoor temp limits 3	
Power connection	4	During defrost 3	
Access to connection terminals	5	Condition to abort defrost	
Circuit Diagram	6	2.9. Bypass	24
Terminal Description	7	Bypass dumper's running time	
Connection Options	8	Outdoor temp. limit of open	
Fireplace Button		Activate ramptime	
ULS, KAVK, CP Heat Etc.		2.10. Cooling recovery	24
Modbus		2.11. Night cooling	25
Remote Panel - With Display		Extended running time.	
Remote Panel 3-Position		Boost cooling	
Remote Panel - Easy (TG-R4)		Conditions night cooling	
Internet		2.12. Forced cooling	26
		2.13. Timer	26
		2.14. KAVK (Condensation boiler)	26
		2.15. I/O configuration	26
		Analog inputs	
		Digital inputs	
		Priority order	
		Timer	
		Stove mode	
		Digital outputs	
		Inverting digital outputs	
		Analog outputs	
		2.16. Modbus	28
		2.17. TCP/IP	28
		2.18. EXOline address	28
		2.19. Remote Panel	29
		2.20. Setpoint Adjustment TG-R4	29
		2.21. Activate Exhaust fan	29
		2.22. Filter Timer	29
		2.23. Cloudigo	29
		2.24. Save Settings	29
		2.25. User Menu	29
		2.26. Zones	29
		Enable Zones	
		Remote Panel Configuration	
		Temperature Menus	
		2.27. Change Alarm Class	30
Operation & Control			
2. Menu table configuration	12		
2.1. Control function	18		
Control Functions			
Cascade Control			
Setpoint Adjustment			
Room Sensors			
2.2. Demand Control	18		
Activate			
Temperature control			
CO2 control			
Moisture control			
2.3. Fan Setup	19		
Fan control			
Setting fan speeds			
Fan delay			
2.4. Temperature control	19		
Setting the controllers			
What are P and I			
Supply air controller			
Room controller			
Exhaust air controller			
Zone control			
Pre-heat controller			
2.5. PID output	20		
Heating, Bypass, Cooling			
Pre-heater			
Duct heater			
2.6. ECO/ECO2	20		
ECO-mode			
ECO2-mode			
ECO adjustment			
Fault safe mode			
Activate ECO2 cooling			
Temp diff.			
Temperature conditions for forcing			
Screen view at boosting and ECO			
Fan curve at ECO/ECO2			

Safety and Security

Please read this manual carefully. Pay special attention to the safety text marked with the exclamation mark above.

Receipt of Delivery

Check that the number of packages matches the consignment note and that there is no transport damage. The ventilation unit must be stored indoors.

If possible, the unit should be kept lying down to minimize the risk of personal injury in case of overturning. Pay special attention to this if children are nearby.

Installation

Work performed by the layman can impair the performance of the ventilation unit and result in injury to person or property. Incorrectly adjusted units will not achieve the desired benefits such as adequate air quality and maximized energy savings.

The unit is heavy. Edges and corners that you do not usually come in contact with can be sharp. Use gloves when moving the unit.

Keep an eye on children. An unassembled unit can easily tip over under abnormal loads.

Mounting

The ventilation unit is mounted upright in the utility room, laundry room or the like. The unit is designed to stand in frost-free space, which is extra important when using condensate drains.

Ensure that there is a stable and level surface on the installation site. If the unit is placed on wooden floors or other moisture-sensitive materials, the unit must be placed on a water-resistant substrate (type Temovex Art. No. Q100490) to prevent marks and moisture damage if possible. leakage or condensation. (See next paragraph for assembly.) It is an advantage if the unit can be placed at least 10 mm away from the wall. This is to minimize the risk of muffler noise. We recommend that the walls of surrounding rooms also be soundproofed. These precautions should be maintained despite the fact that Temovex units are generally very quiet. The unit is equipped with adjustable rubber feet and well balanced fans, to avoid vibration.

The unit should be installed in such a way that it is easy to access for maintenance and inspection. Make sure the door at the front can be fully opened. The unit must be placed so that it cannot be flushed with water during operation. As an option, the unit can be provided with protection that allows the installation to withstand IP class X5.

Installation of Water-Resistant Substrate Q100490

The ventilation unit is often installed in a corner or next to another cabinet. In this case, there are two sides to support the Water-Resistant Substrate. The third side is created with suitable wooden strip which is attached to the floor with eg double-sided adhesive tape, glue, screw etc. Cut the Water-Resistant Substrate to a width of 545mm (485mm + 30mm fold in each side). Cut the same amount on each side. Otherwise, follow the instructions that come with the underlay.

Anti-tip Protection

If it is judged that there is a risk that the unit may tip forward, there is a tip guard as an option. This is then fixed to the back of the unit and screwed during installation in the wall behind the unit.

Condensate Drain

The unit is equipped with a condensation drain at the bottom of the unit. This should be connected to a drain or routed to a floor well. Make sure that the condensation line is placed far enough down in the floor well, otherwise it can draw cold air from it. The condensation line does not need to be fitted with a water trap. The condensate drain has to be connected when the unit is installed. If the unit is equipped with condensation boiler (KAVK) no external connection is needed.

The Duct System

For shorter adaptations between, for example a roof hood and the duct system, a flexible duct called "Drasuten" can advantageously be used. Tumble dryers and drying cabinets must not be connected directly to the duct system.

Placing of Temperature Sensor

The four duct sensors are color-marked at both ends as follow:

Outdoor air = blue

Supply = red

Extract = green

Exhaust = yellow

At delivery, all temperature sensors are electrically connected to the control system. The extract and exhaust air sensors are also pre-mounted in the AHU's respective air ducts.

The outdoor air and supply air sensors must be mounted during installation in respective duct.

The supply air sensor should be placed in the supply air duct, at least 0,6 m from the heater to avoid direct heat radiation, and after the first bend if possible, where the temperature is more homogeneous.

The outdoor air sensor should be placed as far from the unit as possible (as far as the cable allow).

Remember to seal the holes carefully.

If the unit is equipped with a water battery, the anti-freeze sensor is also pre-mounted and connected.

If a room sensor is used, it should be placed approx. 1,4 m above the floor in the living room, preferably on an interior wall.

Insulation

Outdoor air and extract air ducts in heated spaces must be insulated against condensation along their entire length, using an insulation sleeve minimum PE30. The diffusion barriers are sealed with ventilation tape.

Supply and exhaust air ducts in warm rooms do not need to be insulated against condensation, however, heat insulation may be appropriate. Decided on a case by case basis.

If the supply and exhaust air ducts are placed in cold or unheated spaces, they shall be heat insulated. If insulation mat is used, a total thickness of at least 120 mm should be achieved. The insulation should be shared in two layers with overlapping joints.

If placement in loose wool, the cover layer over the ducts should be at least 150 mm.

Open Fireplace

Most modern fireplaces and the like have a separate outdoor air connection which provides the combustion chamber with combustion air. If this is not available/possible, a separate outdoor air diffuser needs to be fitted. The stove consumes between 150-300 m³/h.

To make it easier to start the stove (ignition, the fireplace door is open), the Temovex unit can be equipped with the option "stove function".

Power connection

The AHU is provided with a grounded plug. Connect the plug to an earthed 1-phase socket (230 VAC / 10 A). Connection at the top of the unit.

Access to connection terminals

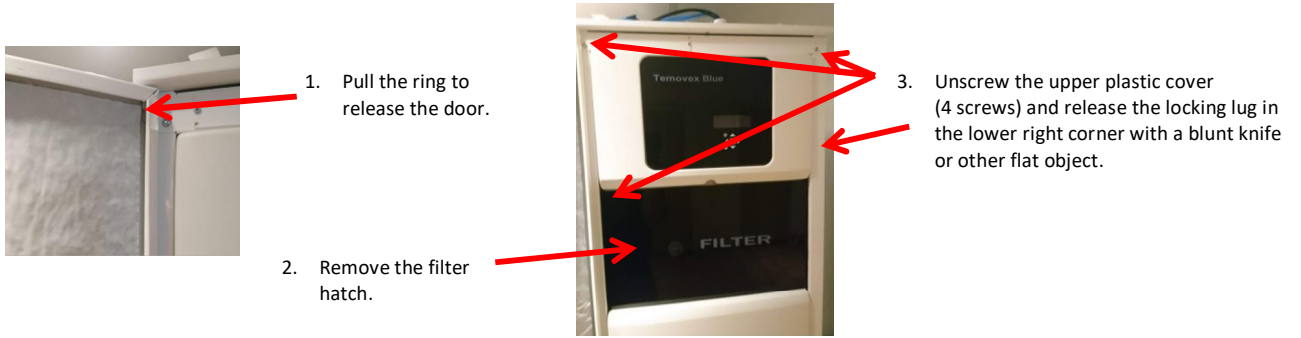

1. Pull the ring to release the door.
2. Remove the filter hatch.
3. Unscrew the upper plastic cover (4 screws) and release the locking lug in the lower right corner with a blunt knife or other flat object.

4. The PCB is now easily accessible for installation of desired functions.

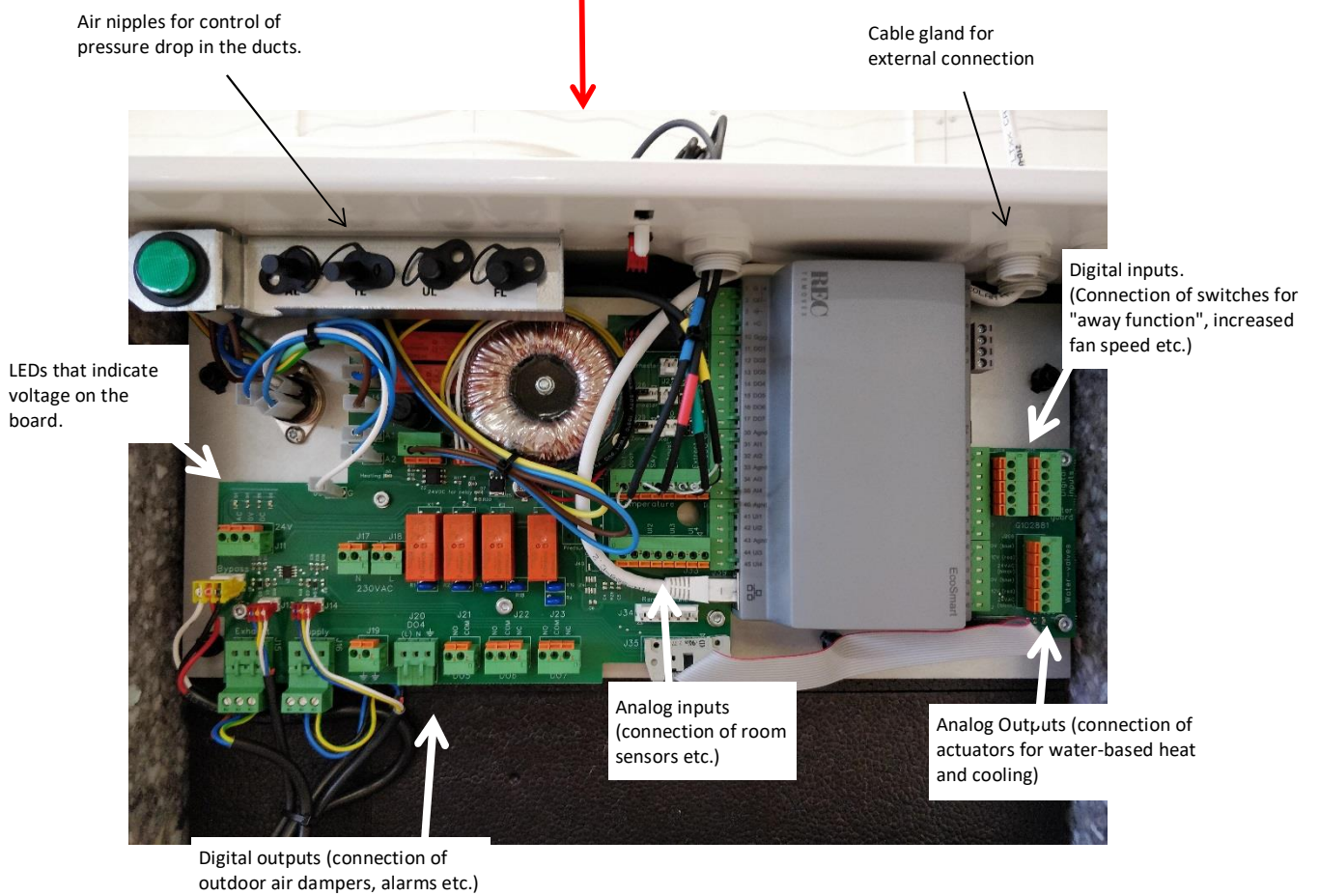

Circuit Diagram

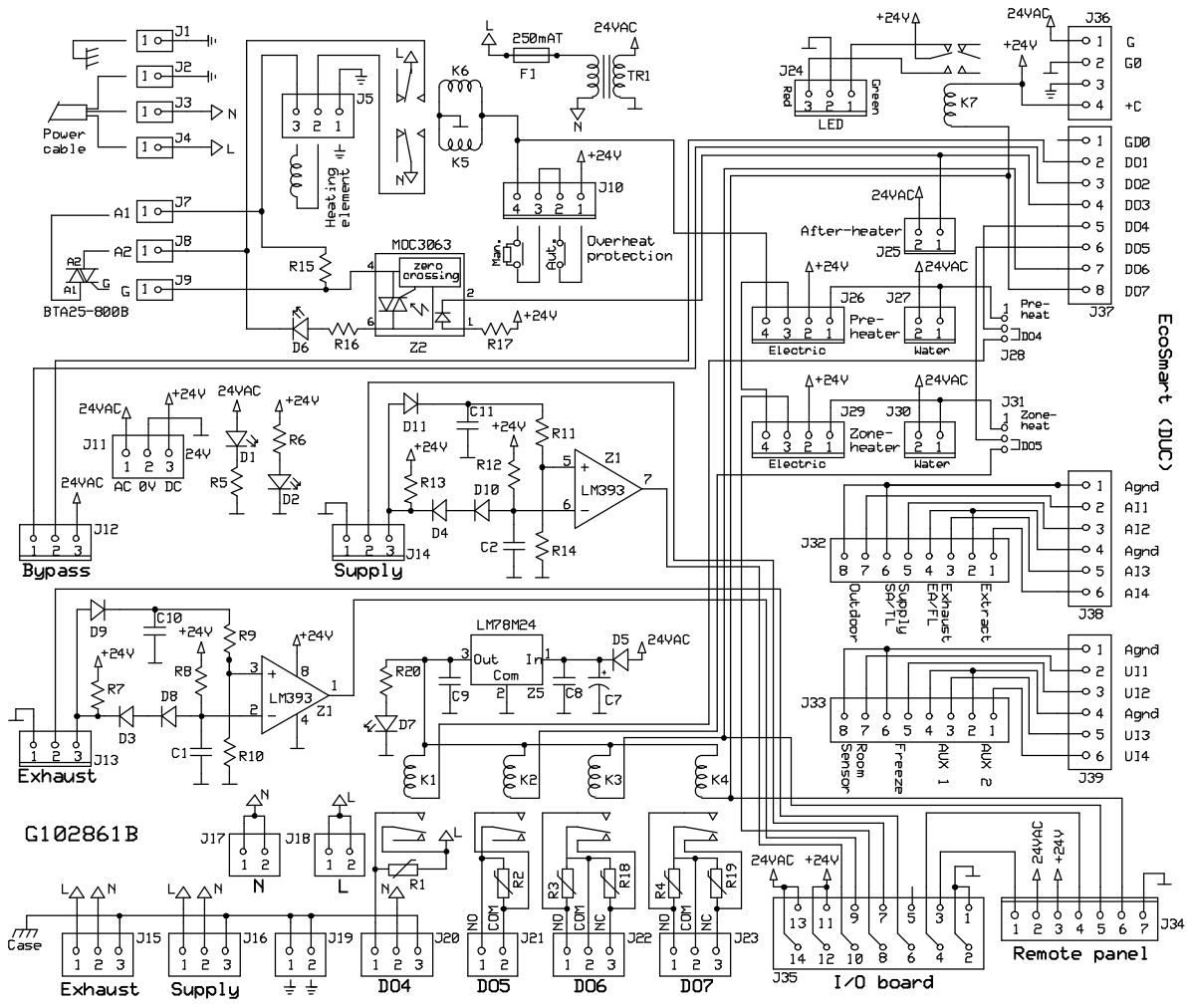

Main card

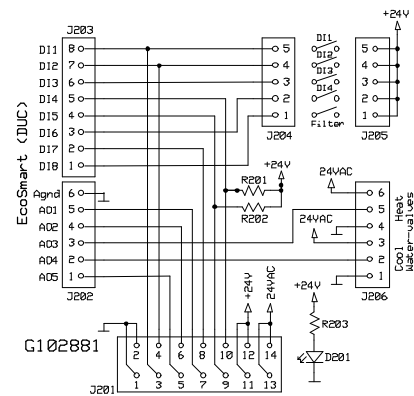

I/O card

Status LED

Terminal Description

General information

Most connections are made on the circuit boards. There are also texts that indicate where different things should be connected. All terminals have a J xxx no. indicated and a small triangle at pin 1.

When stated below, for example, J26/1,2 is meant to be connected to terminal J26 on pins 1 and 2.

In some cases, there are also signal markings on the card.

Room sensor (Terminal J33/7.8)

If room sensor is to be used, keep in mind that room control must be selected in the configuration of the system.

External cooling (Terminal J206/1,2,3)

The system also has ability to handle an external water-cooling battery, e.g., natural cooling from boreholes.

The cooling battery is controlled via an external valve (0 - 10 V).

After heater water (Terminal J206/4,5,6)

The water heater is controlled via an external control valve 0-10V (Possibly is the cable already connected at delivery).

Temperature sensor (Terminal J32)

Temperature sensors (PT1000) for **outdoor air**, **supply air**, **extract air** and **exhaust air** are already connected at delivery.

Freeze protection (Terminal J33/5.6)

To prevent freezing of the water battery in the case of water heating, a freeze protection sensor (temperature sensor) is placed on the return line from the water battery.

Remote panel (Terminal J34)

Terminal for connecting a remote control (optional) with among other things alarm indication and a switch for ECO mode.

NOTE! When using ECO Remote, DO6 must be configured for Normal flow, DO7 for Sum alarms and DI2 to ECO.

Fans power supply (Terminal J15 and J16)

Connection terminals for power supply to the fans. These are already connected at delivery.

Fans control signals (Terminal J13 and J14)

Connection terminals for control signals to the fans. These are already connected at delivery.

Bypass (J12)

Connection terminal for the bypass damper. The cable is already connected at delivery.

Electric heater power supply (J5)

Pin 1 PE, pin 2 neutral, pin 3 phase.

Electric heater overheat protection (Terminal J10)

Electric heater triac connection (J7, J8, J9)

Electric preheater control signals (Terminal J26)

In case of electric preheating, J28 should be in preheat position. Otherwise "DO4". (In case of electric preheating, DO4 cannot be used).

Electric zone heater control signals (Terminal J29)

In the case of electric zone heating, J31 must be in the "zone heat" position. Otherwise "DO5".

After heater water (wax actuator) (Terminal J25)

Preheater water (wax actuator) (Terminal J27)

Zone heater water (wax actuator) (Terminal J30)

DI1, DI2, DI3 and DI4 (Terminal J204 and J205)

There is, as an option, the possibility to connect four external switches which at closing change the fan speeds according to the choices made during configuration. Appropriate flows are preset but can be changed by a qualified installer via the control panel.

For available choices see section "Operation & Control".

Option terminal filter guard (J204.1 and J205.1)

Relay output DO4 (Terminal J20)

This output has a closing function for 230VAC and is suitably used for outdoor air dampers, KAVK or other 230VAC consumers. For configuration see section "Operation & Control".

Relay output DO5 (Terminal J21)

This output has a free closing function that can be used for either 230VAC or 24V. For configuration see section "Operation & Operating".

Relay output DO6 (Terminal J22)

This output has a free closing function that can be used for either 230VAC or 24V. For configuration see section "Operation & Control".

Relay output DO7 (Terminal J23)

This output has a voltage independent NO-NC function that is configured as a sum alarm at delivery.

It is quite possible to use the output for other functions, but then the status LED above the door does not work, since it is connected to the same output, but with a separate relay. If the output is to be used for anything other than a sum alarm, we recommend disconnect the LED so as not to get misleading information. This is easily done by removing the cable to the LED.

For configuration see section "Operation & Control".

LED output status LED. (Plint24)

Mains voltage (Terminal J2, J3, J4)

230VAC, 50Hz

Chassis (Terminal J1)

Ground connection to chassis

Socket low voltage (Terminal J11.)

Power outlet (Terminal J17, J18, J19)

Connection Modbus

See also section 2.16 of this manual.

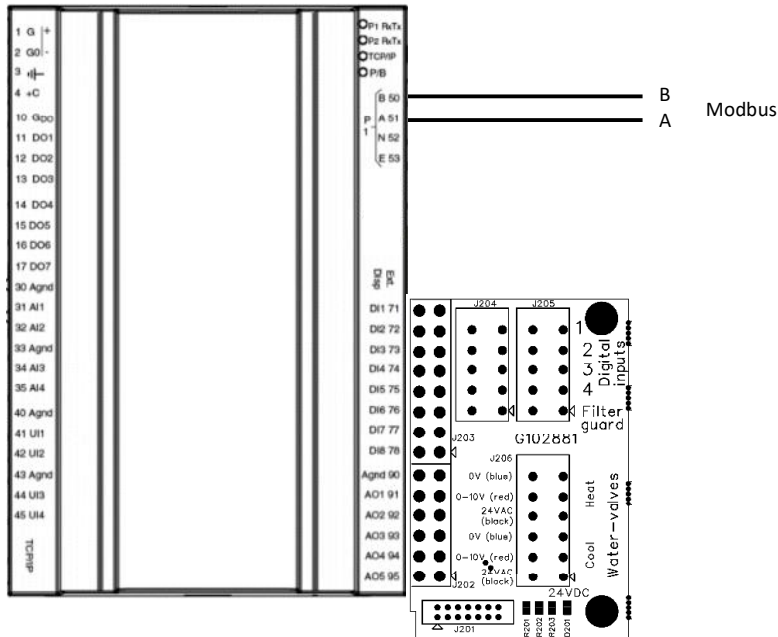

Connection Remote Panel - With Display

You cannot have both Modbus and remote panel. To connect a remote panel with a display, Modbus communication must be deactivated. Contact REC.

Remote panel with display can be connected according to below.

Remote panel	PCB/DUC
10	J11/1
11	J11/2
42	P1/A51
43	P1/B50

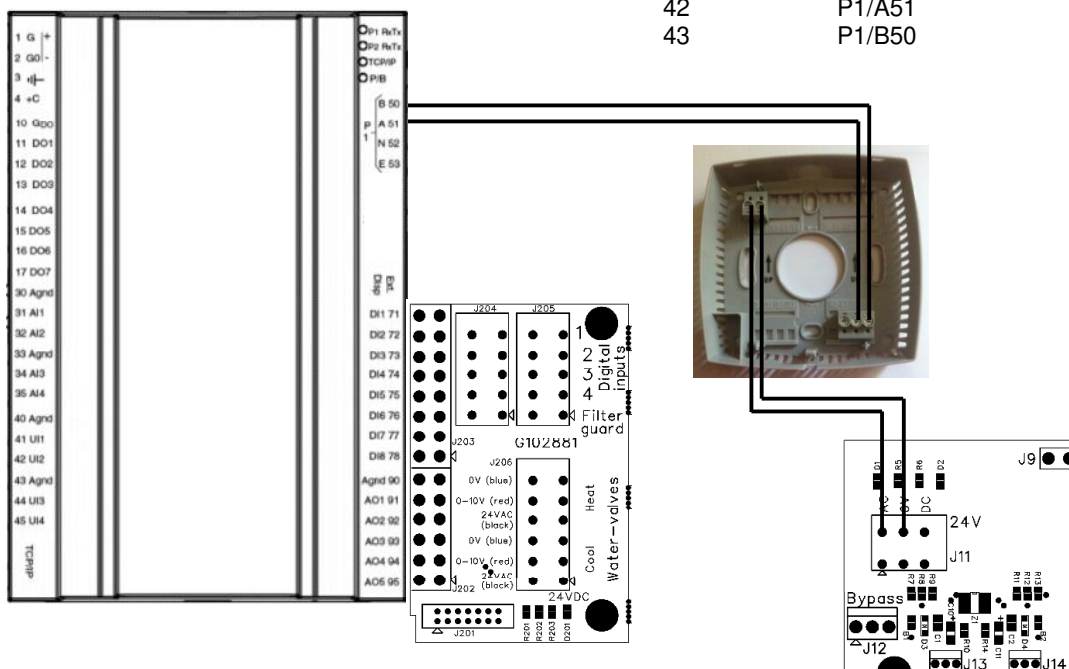

Remote panel - 3-position

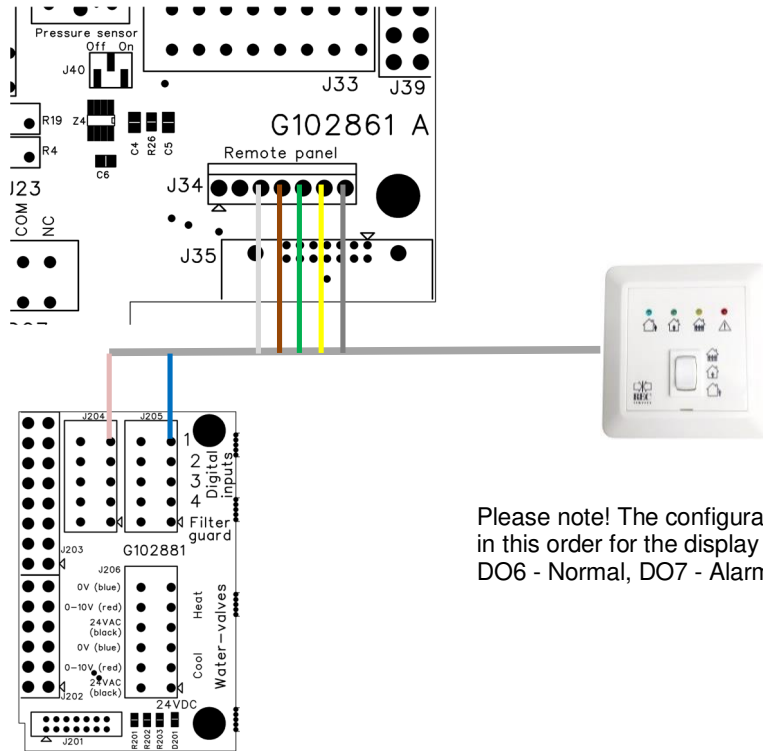

Please note! The configuration of inputs and outputs should be in this order for the display to work:
DO6 - Normal, DO7 - Alarm, DI1 - ECO, DI2 - Forc

Remote Panel - Easy (TG-R4)

Remote panel	PCB
1	J33/8
2	J33/7
3	J33/4
4	J33/3

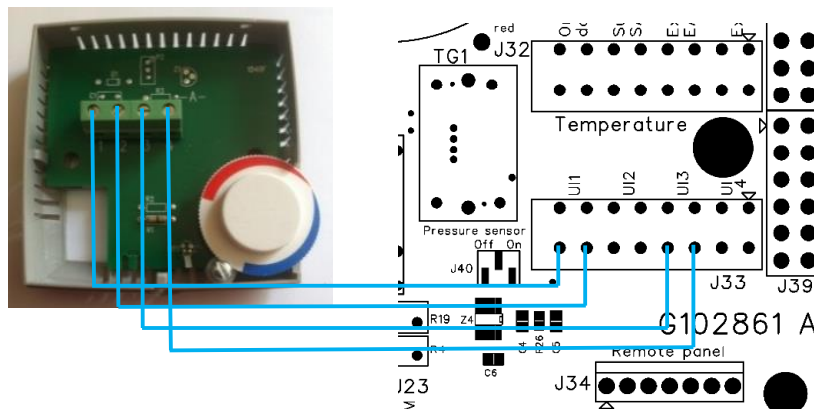

Internet connection (Cloudigo)



An internet cable is plugged into the unit and extended outside.
Connect an internet cable between the adapter and your router.

For initial information see the User Manual!
 Start at Authorization and log in as Technician with code 2222.

2. Menu table configuration

Not relevant for Blue (should not be selected)

Parameter	Standard setting	Changed setting of this unit
2.1. Control function		
2.1.1. Control function	SA control	<input type="checkbox"/> ODT comp. SA control, <input type="checkbox"/> Casc. room control, <input type="checkbox"/> Casc. EA control
2.1.1.1. When cascade control max/min SA setpoint		
Max	52,0	

	Night cool	55 %	_____ %
	Max	100 %	_____ %
	Fire	100 %	_____ %
2.3.2.2.1. Delay EA fan			
	Start	0 sec	_____ (0

		Start temp.		
		Dead band valve	0,5 %	_____ % (0

The timer controls

Min flow

ECO, Boost, Max, AHU On/Off

2.14. KAVK/Condensation boiler *(is displayed if*



After time

12 hours

_____ h (0

	Activate	No	<input type="checkbox"/> Yes
2.21. Activate EA-fan			
	Activate EA-fan	Yes	<input type="checkbox"/> No
2.22. Filter timer			
	Activate Filter timer	Yes	<input type="checkbox"/> No
	Number of days since start	(Current value)	_____
2.23. Cloudigo			
	Activate Cloudigo	No	<input type="checkbox"/> Yes
2.24. Save settings			
	Save current settings	No	<input type="checkbox"/> Yes
2.25. User menu			
	Temperature	On	<input type="checkbox"/> Off
	Mode	On	<input type="checkbox"/> Off
	Timer	On	<input type="checkbox"/> Off
	In/outputs	On	<input type="checkbox"/> Off
	Hand/Auto	On	<input type="checkbox"/> Off
	Alarm history	On	<input type="checkbox"/> Off
	Load settings	On	<input type="checkbox"/> Off
2.26. Zones			
	Activate 2 Zones	No	<input type="checkbox"/> Yes
2.26.1. Configure external display			
	Configure Livingroom (Connect ONE external display)		
	Configure	No	<input type="checkbox"/> Yes
	Configure Bedroom (Connect ONE external display)		
	Configure	No	<input type="checkbox"/> Yes
2.27. Change Alarm Class			
	Alarm		
	Sensor error OD temp	A	<input type="checkbox"/> B, <input type="checkbox"/> C, <input type="checkbox"/> Inactive
	Sensor error SA temp	A	<input type="checkbox"/> B, <input type="checkbox"/> C, <input type="checkbox"/> Inactive
	Sensor error EXT temp	A	<input type="checkbox"/> B, <input type="checkbox"/> C, <input type="checkbox"/> Inactive
	Sensor error EA temp	A	<input type="checkbox"/> B, <input type="checkbox"/> C, <input type="checkbox"/> Inactive
	Sensor error Room temp	A	<input type="checkbox"/> B, <input type="checkbox"/> C, <input type="checkbox"/> Inactive
	Sensor error FRP temp	A	<input type="checkbox"/> B, <input type="checkbox"/> C, <input type="checkbox"/> Inactive
	Freeze protection alarm	A	<input type="checkbox"/> B, <input type="checkbox"/> C, <input type="checkbox"/> Inactive
	Supply fan failure	C	<input type="checkbox"/> A, <input type="checkbox"/> B, <input type="checkbox"/> Inactive
	Extract fan failure	C	<input type="checkbox"/> A, <input type="checkbox"/> B, <input type="checkbox"/> Inactive
	Preheat damper manual	C	<input type="checkbox"/> A, <input type="checkbox"/> B, <input type="checkbox"/> Inactive
	Electric heater overheated	A	<input type="checkbox"/> B, <input type="checkbox"/> C, <input type="checkbox"/> Inactive
	Filter guard DI8	A	<input type="checkbox"/> B, <input type="checkbox"/> C, <input type="checkbox"/> Inactive
	Chiller manual	C	<input type="checkbox"/> A, <input type="checkbox"/> B, <input type="checkbox"/> Inactive
	Heater manual	C	<input type="checkbox"/> A, <input type="checkbox"/> B, <input type="checkbox"/> Inactive
	By-pass manual	C	<input type="checkbox"/> A, <input type="checkbox"/> B, <input type="checkbox"/> Inactive
	ULS manual	C	<input type="checkbox"/> A, <input type="checkbox"/> B, <input type="checkbox"/> Inactive
	KAVK manual	C	<input type="checkbox"/> A, <input type="checkbox"/> B, <input type="checkbox"/> Inactive
	P1-heating manual	C	<input type="checkbox"/> A, <input type="checkbox"/> B, <input type="checkbox"/> Inactive
	P1-cooling manual	C	<input type="checkbox"/> A, <input type="checkbox"/> B, <input type="checkbox"/> Inactive
	SA fan manual	C	<input type="checkbox"/> A, <input type="checkbox"/> B, <input type="checkbox"/> Inactive
	EA fan manual	C	<input type="checkbox"/> A, <input type="checkbox"/> B, <input type="checkbox"/> Inactive
	SA controller manual	C	<input type="checkbox"/> A, <input type="checkbox"/> B, <input type="checkbox"/> Inactive
	Internal battery failure	A	<input type="checkbox"/> B, <input type="checkbox"/> C, <input type="checkbox"/> Inactive
	Filter alarm	Inactive	<input type="checkbox"/> A, <input type="checkbox"/> B, <input type="checkbox"/> C
	Fire damper alarm	A	<input type="checkbox"/> B, <input type="checkbox"/> C, <input type="checkbox"/> Inactive
	Fire alarm	A	<input type="checkbox"/> B, <input type="checkbox"/> C, <input type="checkbox"/> Inactive
	Sensor error TG-R4	A	<input type="checkbox"/> B, <input type="checkbox"/> C, <input type="checkbox"/> Inactive
	Warning low supply temp	C	<input type="checkbox"/> A, <input type="checkbox"/> B, <input type="checkbox"/> Inactive
	Preheat electric manual	C	<input type="checkbox"/> A, <input type="checkbox"/> B, <input type="checkbox"/> Inactive
	Supply air temp low	A	<input type="checkbox"/> B, <input type="checkbox"/> C, <input type="checkbox"/> Inactive

2.1. Control function

2.1.1. Control functions

Selectable features:

- SA control: The temperature is regulated by the SA sensor only.
- ODT comp. SA control: The temperature is regulated as a function of the SA sensor and OD sensor.
- Casc. Room control: The temperature is regulated as a function of the room sensor and SA sensor.
- Casc. EA control: The temperature is regulated as a function of the EA sensor and SA sensor.

2.1.1.1. When cascade control max/min SA setpoint

This function is only active when cascade room control and cascade exhaust air control is used. The rooms desired set point is set on the room sensor if room control and on the EA sensor if EA control. The system calculates a new supply air (SA) set point based on the control error. In the extreme case (if large control error) this could be very high (or low), which could generate too cold or hot supply air, which could feel uncomfortable. It is possible to limit the SA set point both up and down.

2.1.2. Set point adjust

The menu "Set point adjust" is used together with room sensor with set point adjust included, like Remote panel

2.2.1.1.1. PI-settings temperature

Setting of control parameters.

2.2.1.2. CO2-control

Menu for setting the CO2 setpoint

2.2.1.2.1. PI-settings CO2

Setting of control parameters.

2.2.1.3. Humidity-control

Menu for setting the humidity setpoint

2.2.1.3.1. PI-settings RH

Setting of control parameters.

2.3. Fan setup

2.3.1. Fan control

Selectable features:

- Fixed Speed: The fan is running with a fixed %-value of the maximum speed.

2.3.2. Fan speeds

Menu group for fan speeds. When adjusting, you can balance the correct flows by changing the setting for resp. fan.

2.3.2.1. Supply air fan

In this menu, you set the setpoints for the speeds of the supply air fan, corresponding to the various operating modes.

Fan speed night cooling

The value for night cooling is, on delivery, the same as normal mode. If the value for normal mode is changed, the value for night cooling will be changed too, unless the value for night cooling is actively set to something else. To get them synchronized again, set the night cooling value at the same value as normal mode.

2.3.2.1.1. Delay SA fan

Menu for setting the supply air fan start and stop delay.

2.3.2.2. Extract air fan

Menu like 2.3.2.1. but for the exhaust fan.

2.3.2.2.1. Delay EA fan

Menu like 2.3.2.1.1. but for the exhaust fan.

2.4. Temperature control

In this menu group, you can adjust the control parameters for the different temperature controllers. All controllers are of the PI type with adjustable P-band and I-time.

Setting the controllers

In most cases, it works with the default setting, but if you see a need for it, you can adjust it.

Warning! At the same time, an incorrect setting can cause the system to function very badly.

It is the same supply air regulator in all three cases above. A change follows if you change the control function.

What is P and I?

P-band is the temperature change needed to move the actuator from closed to fully open. A small P-band (= large gain) causes an unstable system. A small temperature change on the sensor generates maximum heat and

provides large overshoots. A large P-band (low gain) on the other hand provides smaller overshoots but will take longer before the correct value is reached. Including an integrator (I-value) in the control loop will provide smaller overshoots. The gain decreases the closer the set point comes.

2.4.1. SA control

The supply air regulator is indirect acting, i.e., the output signal increases with decreasing temperature. With the correct P and I parameter, the temperature at the supply air sensor will be kept constant at the setpoint.

2.4.2. Room control

The room regulator works together with the supply air regulator in so-called cascade regulation. A deviation in room temperature compared to the set point generates a shift of the operating point of the supply air regulator so that the deviation is eliminated.

2.4.3. EA control

The exhaust air regulator works together with the supply air regulator in so-called cascade regulation. A deviation in exhaust air temperature compared to the set point generates a shift of the operating point of the supply air controller so that the deviation is eliminated.

2.4.4. SA Control Livingroom

See section 2.4.1.

2.4.5. Room control Livingroom

See section 2.4.2.

2.4.6. Preheat control

Preheater control parameters.

2.5. PID output

2.5.1. PID output (Heating, Bypass, Cooling)

Here the output from the SA controller is displayed, divided between the three outputs cooling, bypass and heating.

The output from the SA controller 0-100% is divided between the outputs as follow.

Controller output (PID-output)	Cooling	By-pass	Heating
0			

2.5.2. PID output preheat

Menu showing pre-heat output.

2.5.3. PID output duct heater

The line "Heating" shows the equipment of the duct heater. When this has reached 100% and the living room still has not reached its setpoint, the bedroom's setpoint is shifted (increased) little by little, causing the unit's built-in heater to increase so that the living room's setpoint is reached. How many degrees the displacement is now can be seen on the last line.

2.6. ECO/ECO2

ECO-mode

- ECO can be used together with all control functions.
- ECO saves energy when nobody is at home. The fans go down to minimum flow.
- ECO means that the fans, when they go on min. flow, increase speed up to normal flow, to carry more heat or cool if min. flow cannot hold the set point.
- ECO-boosting together with cooling works even without cooler. The AHU takes cold air through the bypass only and will cool as far as possible.

- ECO-mode can be activated in different ways, either by a manual switch connected to a digital input or automatically according to a time schedule. ECO can also be activated manually in the mode menu.

ECO2-mode

- ECO2 is used only together with EA and room -control.
- ECO2 means that the fans increase the speed more than with ECO alone. They increase all the way to boost-flow, to carry more heat or cool if actual flow cannot hold the set point.
- ECO2-boosting together with cooling, works even without cooler. The AHU takes cold air through the bypass only and will cool the room as far as possible.
- ECO2 works just as well in ECO mode (when nobody home), as it does when you are at home and the unit is running at normal flow.
- ECO2-boosting together with cooling can be turned off, if you want boosting together with heating only.

ECO-adjusting

- ECO-adjusting is only active with EA- and room-control.
- ECO-adjusting needs ECO to be activated.
- ECO-adjusting indicates a temperature range where heat and cool is inactive. E.g., with ECO-adjust 2° C and a set temp of 20° C, the heat and cool will be inactive between 18° C and 22° C.

Safe mode

- To make it possible to heat/cool with air, it is necessary that enough heat/cool is available through the heater/cooler.
- Safe mode is an extra protection function that blocks the boosting, in the event of lack of heating / cooling media. The aim is to bring as little unwanted cooling / heating to the apartment as possible during a possible unit failure, but still have some ventilation. The fans regulate down towards minimum flow, pending the return of heating / cooling media. It is a continuous regulation, which means that if there is not enough heat/cool, the fans speed up only as much as the heat/cool allows to give a positive heat/cool supplement.
- In the absence of heating media, the unit gives the alarm "Warning low supply air temp". See further at the point alarm delay below.
- Safe mode is only active in exhaust and room control and if ECO and / or ECO2 are installed at the factory. The setting menus for this are displayed only if ECO and / or ECO2 are installed.

2.6.1. Activate ECO2 cooling.

If you wish to use ECO2 cooling, change No to Yes.

2.6.2. Temp. diff.

In this menu, you set how fast the fans shall increase to boost flow. There is a dead band, before the fans start to increase at all. I.e., this is how much the actual temperature may differ from the set point before the fans start to increase the flow. The same dead band applies to both heat and cold. The value for heat and resp. cooling means how many degrees further, in addition to the deadband, which the actual value is allowed to deviate before the fans must have reached forced flow. The fans advance proportionally to the temperature deviation within the range specified.

2.6.3. Temp. diff for increase to boost.

Here you specify how much warmer (or colder) the supply air must be to allow boosting. Example: with a setting for heat 1 degree, the fans will start to regulate towards minimum flow when the supply air temperature is one degree above the exhaust air, and then reach min flow when supply air and exhaust air temperature are equal.

The table below specifies how the fans regulate in different conditions.

ECO Factory setting	ECO2 Factory setting	ECO-mode	Heating requirement	Cooling requirement
-	-	-	Normal	Normal
Yes	-	-	Normal	Normal
Yes	-	Yes	Min → Normal	Min → Normal
-	Yes	-	Normal → Boost	Normal → Boost if ECO2 cooling is activated
Yes	Yes	-	Normal → Boost	Normal → Boost if ECO2 cooling is activated
Yes	Yes	Yes	Min → Boost	Min → Normal and → Boost if ECO2 cooling is activated

2.6.4. Alarm delay.

In the absence of heating media, the unit gives the alarm "Warning low supply air temp" when the fan speed has been at min-flow as standard for at least 5 min. The time can be set in this menu. The alarm is acknowledged and returns automatically as soon as the heat returns. No alarm is given in the absence of cooling.

Screen view at boosting and ECO.

At fan speed between min and normal: ECO.

At fan speed normal: Normal.

At fan speed between normal and boost: ECO2.

Example of fan curve at ECO, ECO2 and ECO+ECO2 (The value below is used in the example).

NOTE! ECO is only permitted when nobody is at home.

With no ECO-functions activated the fans work at normal flow all the time.

The following values have been used in the example below.

ECO adjust: 2,0°C

Dead band: 0,5°C

Temp diff. heating: 1,0°C

Temp diff. cooling: 2,0°C

ECO2 cooling activated

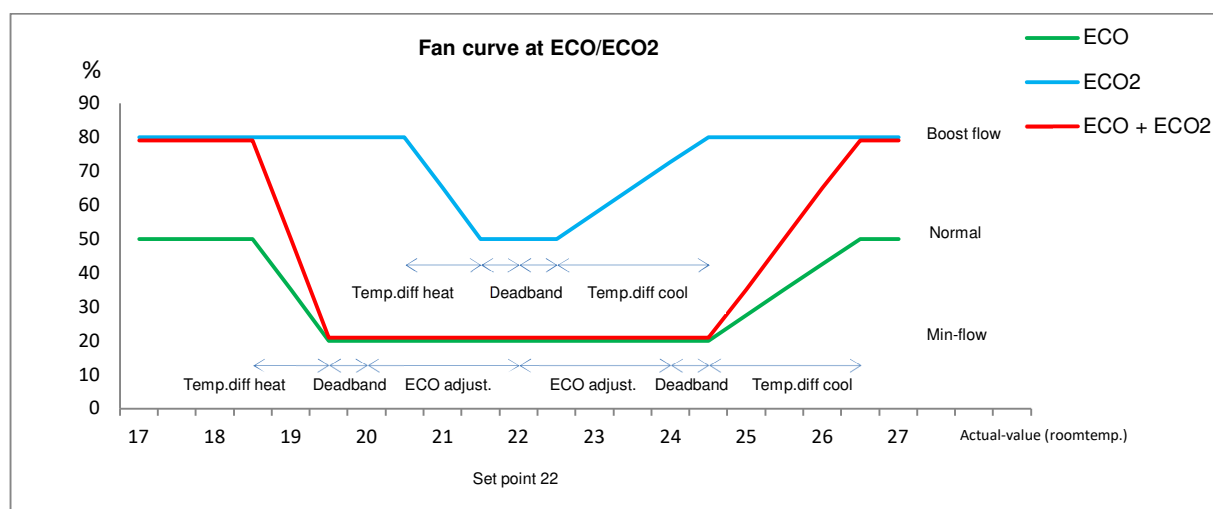

2.7. Heater

2.7.1. Type of heater.

In this menu, you select the type of reheater that is installed in the unit.

2.7.1.1. Electric.

The only setting for electric heating is the period time.

Example: With a heat distribution of 50% and a period time of 60s, this means that the heat is switched on for 30 s and then switched off for 30 s, etc.

Electric heating controls both digital output DO3 (PWM) and analog output AO3 (0-10V).

2.7.1.2. Water (PWM)

Water (PWM) is intended for so-called wax actuators of the ON/OFF type which are controlled proportionally with a PWM signal.

Freeze protection control.

Water heating entails a risk that the water may freeze if the hot water supply fails. Therefore, the AHU is equipped with a freeze protection sensor and a freeze protection controller.

The water temperature is measured close to the water heater with a freeze protection sensor (PT1000) clamped on the return pipe and then isolated.

There is a freeze protection control 0-100% according to a linear scale, between start value and alarm temperature plus 1 degree. The heat level will be whichever is the higher of the normal temperature controllers

2.8.2. Outdoor temp. limits.

Limit settings for outside temp. range 2.

2.8.2.1. During defrost.

Defrost settings range 2.

2.8.3. Outdoor temp. limits.

Limit settings for outside temp. range 3.

2.8.3.1. During defrost.

Defrost settings range 3, during supply air control.

2.8.3.2. During defrost.

Defrost settings range 3, during extract air control and room control.

2.8.4. Conditions to abort defrost.

If the difference between supply air temperature and exhaust air temperature is no longer that large, it is a sign that the need for defrosting is no longer present. Defrosting is interrupted.

2.9. Bypass

2.9.1. Bypass damper

Requirement	Cool	Cool	Heat	Heat
OD air	>EA+2	<EA+2	>EA+2	<EA+2
Bypass	Regulates towards closed to cold exchange the cooler inside air.	Regulates towards open to cool with the colder outside air.	Regulates towards open to heat with the warmer outside air.	Regulates towards closed to heat exchange the warmer inside air.

2.11. Night cooling

Night cooling means that at night during the warmer season, cold outdoor air is taken directly into the house to cool down the house and buffer for the warm day ahead.

Night cooling is recommended if warming with air, like EA or room control. But it is also possible to use together with supply air control, as the AHU switches to EA control when night cooling (including after time) is active. This works on conditions that the normal heating equipment has been turned off.

Activating night cooling.

For night cooling to work, it must be activated.

Extended running time.

The heat is off during the part of the extended running time that is within the night cooling activating time. The remaining time the heat is controlled with the room temperature set in the menu "conditions night cooling" as set point. (This to save the newly acquired cool air). If the extended running time would encroach on next day's activating time, night cooling will have priority. If the conditions for night cooling no longer are fulfilled within the activating time, the extended running time will start at this point. If the conditions should be fulfilled again before the activating time ends, night cooling will start again, and the extended running time resets itself. The last row in the menu shows if the activating time is active or not. It is also possible to reset an ongoing extended running time. (If the extended running time is set to 0 hour the time will be 1 min, which makes it easy to test the functions).

Boost cooling.

During the time night cooling is active, boost cooling is disabled. (See chapter ECO including safe mode). Default 22:00 to 06:00. Even if night cooling has ended because the conditions no longer are fulfilled, boost cooling is disabled during the time stated.

In the standard case the fans will run at the same speed (normal speed) all night long (22:00-06:00). In the morning boosting is allowed but still with a low set point (18 degrees) until the extended running time (4 h) has ended, which will be at 10:00h.

2.11.1. Conditions night cooling.

In this setup menu you configure the temperature conditions for night cooling to be active.

2.12. Forced cooling

In supply air regulation, heating is normally handled by another system. The temperature of the supply air is regulated according to the supply setpoint, which is normally a few degrees below the set point for the primary heating system. When using forced cooling, a set value for this is set on the unit. The cooling value setpoint must be one or several degrees above the normal setpoint for the primary heating system.

If the temperature of the extract air rises above the forced cooling setpoint, the unit switches to extract air control and adjusts to the forced cooling setpoint, but only with the help of cooling (no heat is activated). If ECO2 cooling is activated it also forces to cool according to normal ECO2 routines.

There is an adjustable hysteresis and when the temperature eventually drops below the set point minus the hysteresis, the unit switches back to supply air control and adjusts to the supply air setpoint both by means of heat and bypass.

By activating the function, the cold is blocked during supply air regulation and thus only becomes active when the unit switches to extract air control. A time window can be specified if needed.

2.13. Timer

In this setup menu you configure what the timer should do.

Default is Min flow, which means the AHU will go to min flow during the periods set in the menu timer schedule. Normally used as an

Configuring fan type

On DI4 and 5 it is possible to select different types of feedback signal from the fan. These are normally configured from the factory and should not be changed.

It is also possible to disconnect the feedback signal from the exhaust fan to avoid alarms if an external exhaust fan is used without a feedback signal.

There is an adjustable alarm delay for the fan alarms.

2.15.2.1. Timer

A timer could be connected to any of the inputs if a T is activated at any of the rows. There is only one timer. All functions except Not active, Fire damper, Fire alarm and Stove mode can have timer connected.

Connection of timer to desired function

When you have gone through the rows and selected functions for the inputs, the cursor will make one more loop and there is a possibility is to put a T against any of the rows. Use arrow up and down to connect the timer to a specific row. A

2.15.3.1. Invert DO

In some cases, it may be preferred that the alarm relay turns on immediately when the unit gets power, and instead switch off if there is an alarm.

This will generate an alarm if there is an interruption in the power supply.

In this menu one or more outputs can be inverted.

2.15.4. Analog outputs

If the valves do not have a 0-10V input (default), then there are free choices 0.0-10.0V or vice versa 10.0-0.0 in steps of 0.1V.

2.16. Modbus

Connection

Modbus via RS485.

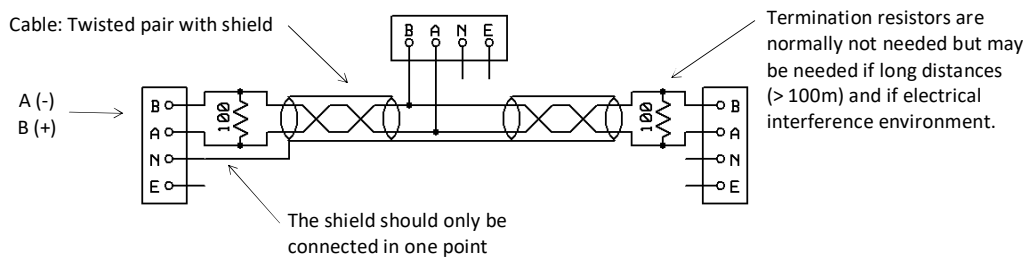

As an alternative, Modbus is also available via the TCP / IP port!

Parameter settings

Modbus is activated by default on port 1, but if a remote panel is to be used, modbus must be deactivated. Modbus via TCP is normally on but should be deactivated if you use a "public network" in cases where you connect the controller to the internet. This is to prevent outsiders from being able to read from the controller.

Complete Modbus list can be obtained from REC on request.

2.17. TCP/IP

Internet setting menu.

2.18. EXOline address

EXO line address setting menu.

2.19. Remote panel

There is only 1 port, and it is configured to Modbus by default. Thus, you cannot have both Modbus and a remote panel.

If a remote panel is ordered at the same time as the AHU, the configuration is done for remote panel at the factory. When ordering a remote panel as supplement later, the Modbus must be deactivated. Contact REC for help with this.

2.19.1. Set point adjust.

Here you can set the limits for how much setpoint adjust. you want to allow via the remote panel.

2.20. Set point adjust. TG-R4

TG-R4 activation menu.

When the TG-R4 is activated, the current setting is displayed on the bottom line.

2.21. Activate EA-fan

Not relevant for Blue (should not be changed).

2.22. Filter timer

The filter timer should not be deactivated!

If you would like to change the time to next filter change, is it possible to adjust the number of days since the timer started.

2.23. Cloudigo

Cloudigo is a system that allows to view and change parameters via the Internet. The system requires a subscription. Contact your supplier for more information!

2.24. Save settings

Here you save all current settings. Earlier saved settings will be lost. All settings are saved except date and time.

2.25. User menu

Use this menu to select which items that should be visible for the user. All items that are visible as default are selectable, except

2.26.1. Configure external display.

Since two remote panels will be connected on the same port, these must be configured as bedroom display and living room display. Plug in one remote panel at a time to configure. When the configuration is complete, "Idle" changes to "Config ok".

When both are configured, you connect both in parallel to the port.

Temperature menus.

When zones are activated, other temperature menus are displayed, see section

Notes:

Medlem i



Svensk Ventilation
Bransch i samverkan

Rec Indovent reserves the right to alter specifications and design without prior notice.



REC Indovent AB

Box 37, SE-431 21 Mölndal, Sweden
Visiting address: Kärragatan 2

Tel: +46 31 67 55 00
Fax: +46 31 87 58 45

www.rec-indovent.se

Certified according to ISO 9001/14001

REC 23-01-23 (pgm. ver. 2.5-1-04)